

Classification Report

Thermal Transmittance

Test report 401 29061/1



Client **AL 7 - MEIPA S.p.A.**
Via Poggio Renatico 1/3

I-40016 San Giorgio di Piano (BO)
Italy

Basis

EN 674 : 1997-11
Determination of thermal transmittance (U -value) – Guarded hot plate method

Product	Insulating glass unit with louver system in cavity
System designation	E.A.SY. Eclisse Aluminium System
Exterior dimensions (w x h)	800 mm x 800 mm
Construction	4 / 24 / 4 mm
Gas filling	Air
Coating	no low-E coating
Louver system in cavity width	Adjustable micro-louver system colour K010 pure white
Special features	--

Representation

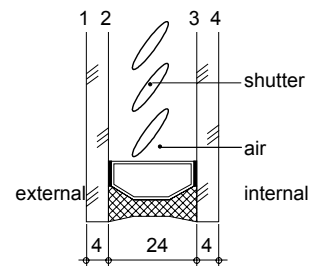

Instructions for use

The present test report serves to classify the thermal transmittance U_g .

Validity

The data and results given relate solely to the tested and described test specimen.

Testing the thermal transmittance does not allow any statement to be made on further characteristics of the present structure regarding performance and quality.

Notes on publication

The ift-Guidance Sheet "Conditions and Guidance for the Use of ift Test Documents" applies.

The cover sheet can be used as abstract.

Contents

The test report comprises a total of 5 pages.

- 1 Object
- 2 Procedure
- 3 Detailed results

Thermal transmittance



Horizontal slats

$$U_g = 3.1 \text{ W}/(\text{m}^2 \cdot \text{K})$$

Vertical slats

$$U_g = 2.1 \text{ W}/(\text{m}^2 \cdot \text{K})$$



ift Rosenheim
01 December 2005

Norbert Sack

i. V. Norbert Sack, Dipl.-Phys.
Head of Testing Department
ift Centre Glass, Building Materials & Building Physics

Konrad Huber

i. A. Konrad Huber, Dipl.-Ing. (FH)
Test engineer
ift Centre Glass, Building Materials & Building Physics



ift Rosenheim GmbH
Geschäftsführer:
Dipl.-Ing. (FH) Ulrich Sieberath
Dr. Jochen Peichl

Theodor-Gietl-Straße 7-9
D-83026 Rosenheim
Tel.+49 (0) 8031 / 261-0
Fax+49 (0) 8031 / 261-290
www.ift-rosenheim.de

Sitz: 83026 Rosenheim
AG Traunstein, HRB 14763
Sparkasse Rosenheim
Kto. 38 22
BLZ 711 500 00

Anerkannte Prüf-, Überwachungs- und Zertifizierungsstelle nach Landesbauordnung: BAY18
Notifizierung in Europa: Nr. 0757

1 Object

1.1 Description of test specimen

Product	Insulating glass unit with louver system in cavity
Manufacturer	AL 7 – MEIPA S.p.A.
Date of manufacture *	22.02.2005
Product designation	E.A.SY. Eclisse Aluminium System
Area-related mass	25.2 kg/m ²
External dimensions (W x H)	800 mm x 800 mm
Design	
Construction	4 / 24 / 4 mm
Total thickness at edge	32.9 mm
Total thickness in centre of pane	31.5 mm
Coating of the surface	no low-E coating
Type / producer	--
Coating level	--
Emissivity	--
Filling in pane space	
Gas	Air
Percent by volume	100 %
Louver system in cavity	
Type, manufacturer	E.A.SY. Eclisse Aluminium System, AL 7 – MEIPA S.p.A.
Design	Adjustable micro-louver system
Width of slats	21.4
Thickness of slats	3.8
Distance between slats	18.4
Material / colour of slats	Aluminium 100% polyester powder coated, K010 pure white
Special attachment	--
Special features	The panel was tested with slats adjusted in vertical and horizontal position.

The description is based on inspection of the test specimen at **ift**. Article designations/numbers as well as material specifications were given by the customer. Additional data provided by the customer is marked with *).

1.2 Representation of test specimen

The structural details were examined solely on the basis of the characteristics to be classified.

The illustration was produced by the **ift** as a schematic representation of the cross section and by unchanged documentation provided by the client.

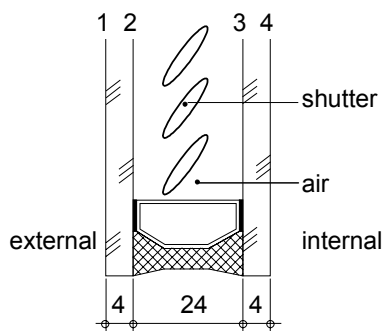

Figure 1 Schematic representation of sample

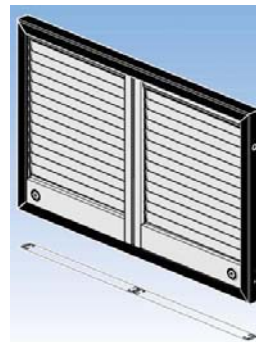

Figure 2 Schematic representation of sample

2 Procedure

2.1 Sampling

The samples were selected by the customer

Quantity	2
Delivered	08 March 2005 by the customer
Registration No.	17942

2.2 Process

Technical basics

EN 674 : 1997-11

Determination of thermal transmittance (U -value) – Guarded hot plate method

Boundary conditions

As specified by the standard requirements

Deviation

There are no deviations from the test procedure and/or test conditions.

2.3 Test equipment

Guarded hot plate	Appliance number: 22001
Position of test specimen	vertical
Direction of heat flow	horizontal
Sensor layout	as specified in EN 674 : 1997-11

2.4 Testing

Date/Period	20 April to 27 April 2005
Testing personnel	Konrad Huber

3 Detailed results

3.1 Detailed results for the insulating glass unit with slats adjusted in horizontal position

Designation			
A	Measuring area	mm ²	500 000
Φ	Input power	W	45.7
$\theta_1 (T_1)$	Mean surface temperature on the warm side of the specimen	°C	17.3
$\theta_2 (T_2)$	Mean surface temperature on the cold side of the specimen	°C	3.8
$\theta_m (T_m)$	Mean temperature of the specimen	°C	14.5
ΔT_m	Mean temperature difference between hot and cold side of the specimen	K	10.0
R	Thermal resistance	(m ² · K)/W	0.159
ε_n	Normal emissivity of surface adjacent to the inner room	-	0.89
ε	Corrected emissivity of surface adjacent to the inner room	-	0.837
h_i	Internal heat transfer coefficient	W/(m ² · K)	8
U_p	Thermal transmittance	W/(m ² · K)	3.1

3.2 Detailed results for the insulating glass unit with slats adjusted in vertical position

Designation			
A	Measuring area	mm ²	500 000
Φ	Input power	W	24.2
$\theta_1 (T_1)$	Mean surface temperature on the warm side of the specimen	°C	17.4
$\theta_2 (T_2)$	Mean surface temperature on the cold side of the specimen	°C	2.4
$\theta_m (T_m)$	Mean temperature of the specimen	°C	15.0
ΔT_m	Mean temperature difference between hot and cold side of the specimen	K	10.0
R	Thermal resistance	(m ² · K)/W	0.314
ε_n	Normal emissivity of surface adjacent to the inner room	-	0.89
ε	Corrected emissivity of surface adjacent to the inner room	-	0.837
h_i	Internal heat transfer coefficient	W/(m ² · K)	8
U_p	Thermal transmittance	W/(m ² · K)	2.1

ift Rosenheim

01 December 2005